



# Picnic tables for events

## EventTable has lots to offer as professional seating:

- Simple, strong and safe design
- Stable on all surfaces – even on wet grass
- Seats eight average sized adults
- Easy access with comfortable seating
- Elegant design, attractive colour
- Wheelchair-friendly
- Easy to assemble
- Easy to clean
- Wide enough for two plates

Call us today on (07) 5525 3545 for a free quote.

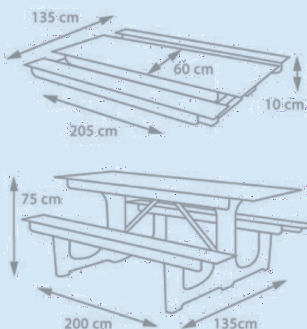

### EventTable dimensions and weight

The EventTable's width and length remain the same when set up or taken down.

The benches are 5cm shorter than the table top, which ensures that the cheeks don't get stuck if the tables are connected lengthways.

If necessary the EventTable can be easily dismantled, splitting the unit into five separate parts for transport.

L x W total	200 x 135 cm
Table top	200 x 60 cm
Bench	195 x 24 cm
Table top height	75 cm
Bench height	45 cm
Stacking height	10 cm
Weight	ca. 45 kg

**SPLASHdown**  
QLD.com.au

QLD Office:  
Tel: 07 5525 3545

**SPLASHdown**  
event services

NSW Office  
Tel: 02 4626 5337

Please read this entire leaflet before removing the tables from the delivery stillage.

 These picnic-style folding tables are designed to seat a maximum of eight average sized adults – they are **not** designed for any other purpose.

## INSTRUCTIONS

1



2



3



4



## ASSEMBLY

1. Release the stillage retaining strap and catch.
2. Carefully lift, then lower the table into place on firm level ground in the unfolded position.
3. Pull firmly on the table release catch located underneath the table top.
4. Pull the table upwards into an upright position, making sure that the support lugs have located into the retaining slots.
5. Push down on the table top to ensure that the table is locked into position and correctly assembled.

**IMPORTANT:** Take out each table one at a time from the stillage. Before removing a table, make sure that the next table is secured by the stillage retaining catch.

## DISASSEMBLY

1. Release the catch located underneath the table top and carefully lower the table to the ground.
2. When fully unfolded, ensure that the lugs are secured and the table is properly locked together.
3. Lift the table to the stillage and secure into the track on the base of the stillage.
4. Secure the stillage retaining catch before loading the next table.
5. When the last table is secured, tighten the restraining strap.

### **EACH STILLAGE HOLDS A MAXIMUM OF 10 TABLES.**

These tables are designed to seat eight (8) average sized adults. These recommendations should not be exceeded, nor should people be allowed to stand on them.

### **BEFORE USE, MAKE SURE THAT EACH TABLE IS FIRMLY LOCKED IN PLACE.**

**DO NOT** stick labels, signs or other similar items to the tables

**DO NOT** secure table cloths or other material onto the table using pins, staples or similar objects.

**DO NOT** stand, dance, jump or slide on the tables.

**DO NOT** place the tables on uneven ground.

**DO NOT** write, scratch or draw on the tables, be careful not to burn the tables.

**DO NOT** exceed eight (8) averaged sized persons seated on each table.

FAILURE TO COMPLY WITH THESE INSTRUCTIONS COULD LEAD TO EXTRA CHARGES BEING MADE.

**If further instruction or help with assembly is needed, call us on (07) 5525 3545.**